



## GWS-WELD STAND ASSEMBLY INSTRUCTIONS

### Part #s

GWS- MOB1 (Mobile Stand)  
GWS-FL1 (Floor Model)  
GWS-B1 (Base Only)



## GOLIATH GWS-WELD STAND SAFETY INSTRUCTIONS

**Please read completely before using the Stand.**

Always use the recommended equipment to prevent damage or failure.  
Do not allow children under the age of 18 years of age to use the stand.  
Do not use the stand for any other purposes than what is described in our manuals and web site.  
Do not use substitute parts. Contact the manufacturer or Goliath Carts for replacement parts.

This product is manufactured by Goliath Carts, LLC.  
P.O. Box 891210  
Temecula, CA 92589-1210  
Toll Free: 866.694.2278  
[www.goliathcarts.com](http://www.goliathcarts.com)

# GOLIATH GWS-WELD STAND ASSEMBLY INSTRUCTIONS

## with Base Stand (optional)

Part #	Qty	Description
A	3	Weld Stand Base Donuts
B	Optional	Weld Stand Base (with Casters) 18" X 24"
C	2	Vertical 2" inch Poles (47" and 36")
D	6	1/4" - 20 X 1.25" Flat Screw
E	2	1/4" - 20 X 3/4" Hex Bolt
F	1	Telescoping Arm
G	9	1/4"-20 X 1/4" Set Screw
H	6	10/32" Wing Head Screw
I	4	1/4"-20 x 3/4" Wing Head Screw
J	1	Coupon Holder Assembly
K	1	Aluminum T-Handle Tool
L	1	Shelf
M	1	Wet Dry Coupon Holder
N	1	White Board

**PLEASE NOTE: THIS STAND IS DESIGNED TO BE ASSEMBLED USING THE TOOL LIST BELOW. DO NOT USE POWER TOOLS TO ASSEMBLE THE CART AS IT MAY DAMAGE THE PRODUCT.**

### **Tools Needed:**

- **Phillips Head Screwdriver, 1/4"-20 Allen Wrench, Crescent Wrench, Weld Stand T-Handle Tool (included)**

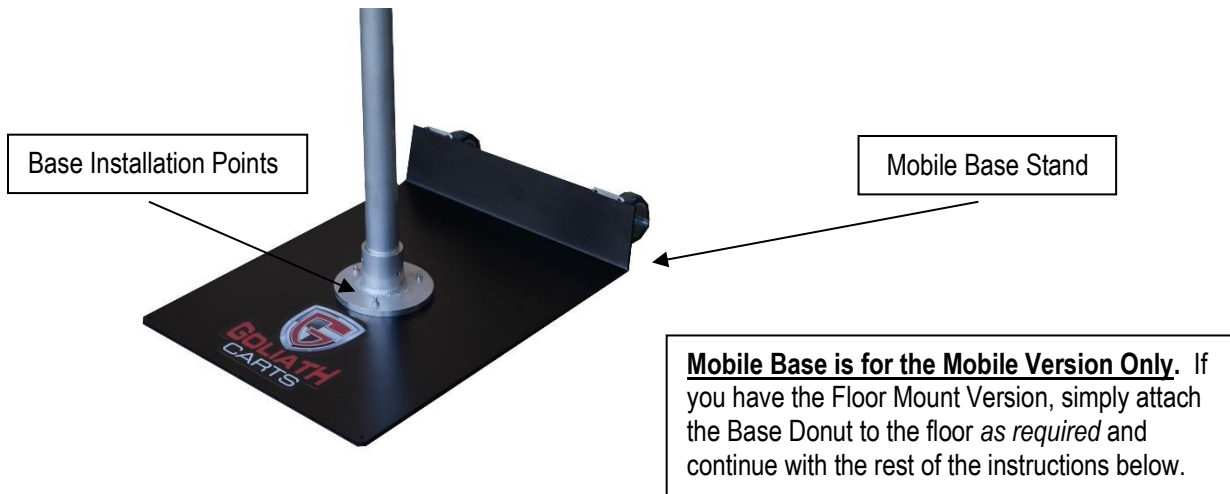

### **STEP 1: Attach the Weld Stand Donut to the Weld Stand Base then Attach Upright #1**

1. Attach the Weld Stand Donut (Part A) to the Caster Base (Part B) or to the Ground if installing as a Floor Mount. Secure from the underside of the Base Stand with (3) 1/4" -20 X 1.25" Flat Screws (Part D).
2. Install 36" Vertical Pole (Part C) and tighten the (3) 1/4"-20 X 1/4" Set Screws (Part G).

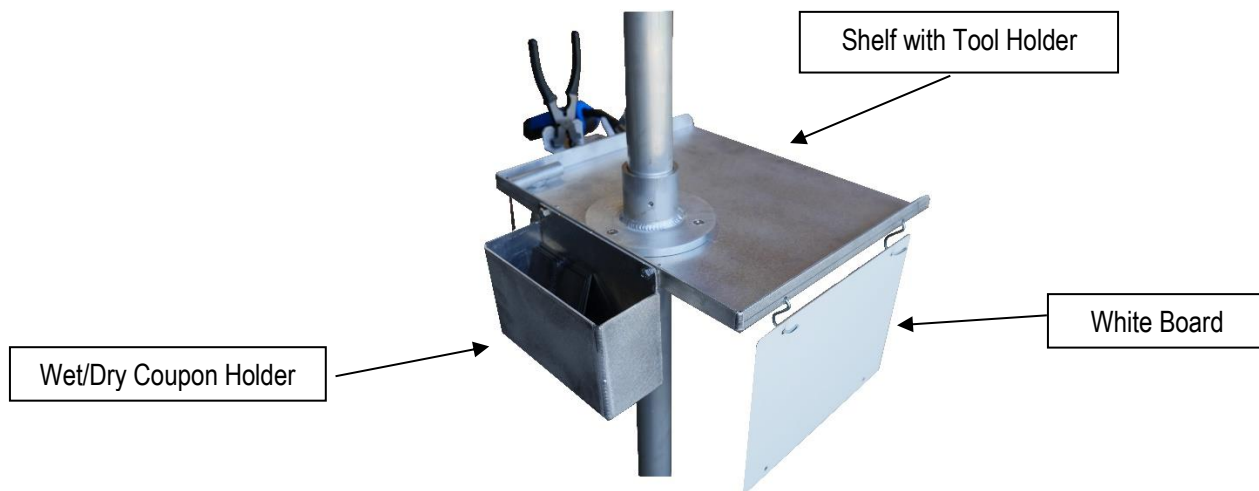

**STEP 2: Install Shelf Between 2 Donuts, Install Wet/Dry Coupon Holder, and attach Whiteboard**

1. Attach a Weld Stand Donut (Part A) to the top of the 36" Weld Stand Pole (Part C) and tighten the (3) 1/4'-20 X 1/4" Set Screws (Part G). Set the Side Shelf (Part L) on top of the Weld stand Donut and line up the holes and then top with the final Weld Stand Donut. Secure the 2 Donuts between the Shelf using (4) 1/4-20 X 1/1/2" – screws (Part D).
2. Install the Wet/Dry Coupon Holder (Part M) on the shelf using the (2) 1/4-20 X 3/4 Hex Bolts (Part E)
3. Install the Dry Erase Board (Part M) on the provided Hooks

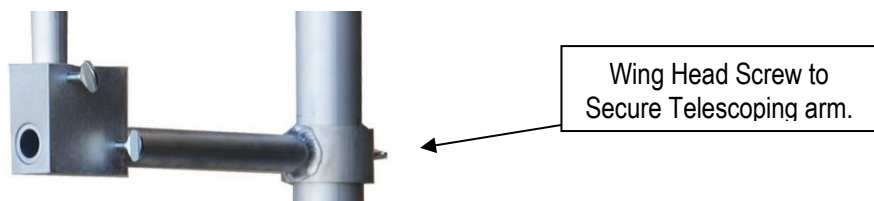

**STEP 3: Attach Top Upright (47" Long Pole) and Arm assembly for Coupon Holder**

1. Install 47" Vertical Pole (Part C) and tighten the (3) 1/4'-20 X 1/4" Set Screws (Part G).
2. Slide the Coupon Holder Arm down the Vertical Pole and secure at the desired height using (4) – 1/4 - 20 X 3/4" Wing Head Screw, (Part I) Tighten using the included T-Handle Tool (Part K)

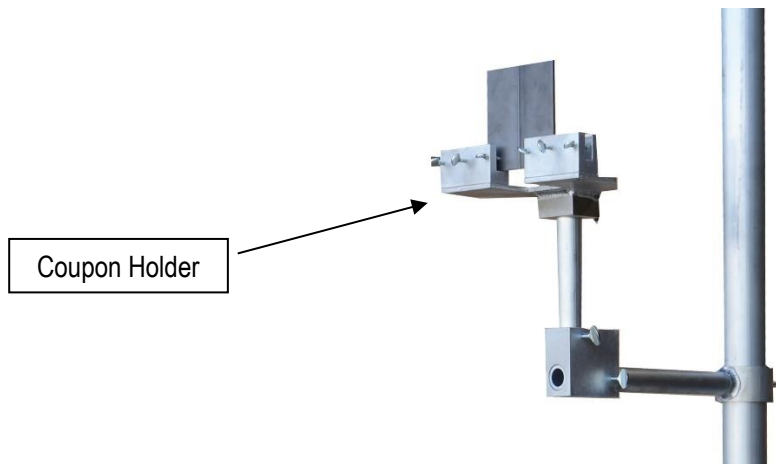

#### **STEP 4: Attach Coupon Holder**

4. Slide the Coupon Holder (Part J) on to the small Arm Tubing and secure using (4) – ¼ - 20 X 3/4" Wing Head Screw, (Part I) Tighten using the included T-Handle Tool (Part K)

**GWS-WELD STAND with w/ STAND INSTALLATION IS COMPLETE.**

**You can now start using the Goliath Carts Weld Stand. Coupons can be inserted and secured using the Wing Head Screws. Please make sure to tighten with the included T-Handle Tool.**

**We have FAQ's and Technical Documents on our website  
Visit us online at [www.goliathcarts.com](http://www.goliathcarts.com)**